

FOGIA.

Handmade Scandinavian Design
PREMIUM FURNITURE SINCE 1981

Amateiems
Studija

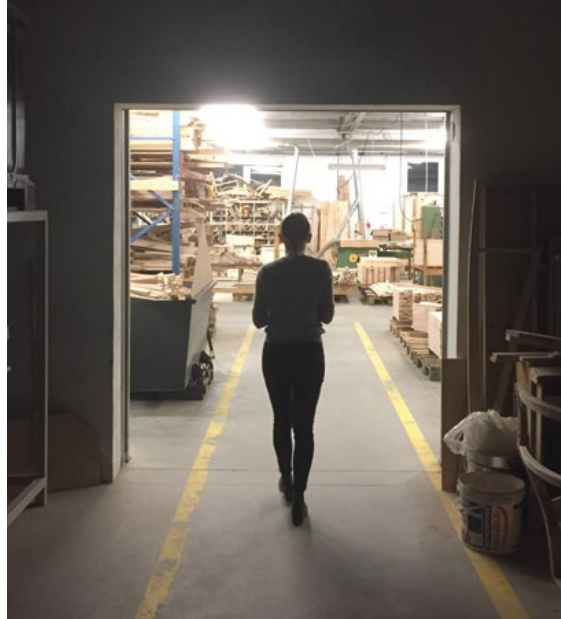



LASTING SENSATIONS

Fogia – based in Stockholm – is one of the leading Swedish furniture brands. From our beginnings back in 1981, we have collaborated with some of the most recognised designers in Scandinavia. Our pieces are crafted from the ground up in our own factory by fusing fine craftsmanship and contemporary technology.

Fogia believes that design is the sum of three parts. Quality, feeling and good craftsmanship. Blend intelligent material selection with impeccable craftsmanship and you get quality. Feeling is a little trickier though; special yet intangible, a sensation that grows stronger through time. That's why we manufacture our furniture ourselves in our factory, with attention to every detail, instead of sourcing poor quality from the cheapest spot. Fogia collaborators have worked to create pieces that distil quality, craftsmanship and feeling into furniture and accessories that fuel the senses today and for many years to come.

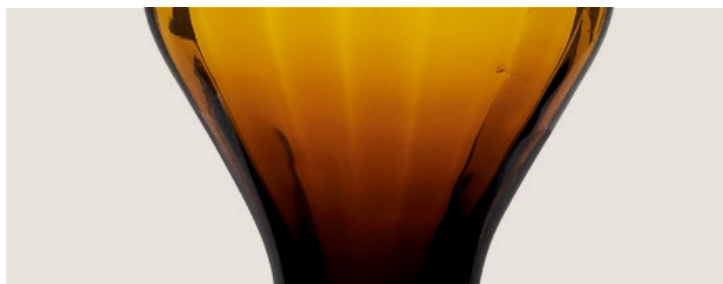

Luft

LUCA NICHETTO

LUFT is a range of vases created by Luca Nichetto, hand blown on Murano island, Italy, where the designer himself comes from. Here, Foggia's craftsmanship is intertwined with the designer's own roots. The name LUFT is taken from one of the elements – *air* – the inspiration for the shapes of the hand-blown glass.





Jord

LUCA NICHETTO

The name JORD means Earth in Swedish. One of the four fundamental elements, it is inspired by the sofa's low seat height and its expansive, wide shape. JORD is a modular sofa offering countless combination options, designed as a flexible sofa system that can be used in the home or in public spaces.





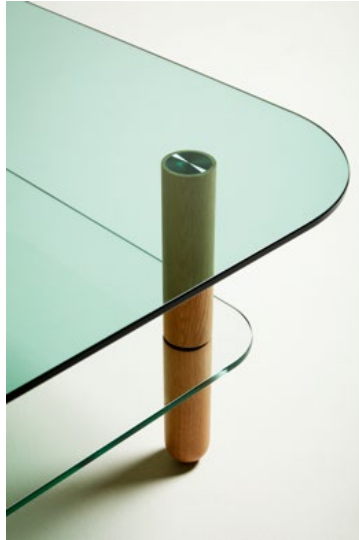

Big Sur

SIMON KLENELL | KRISTOFFER SUNDIN

Carpenter and furniture maker KRISTOFFER SUNDIN and glass designer SIMON KLENELL collaborated to create BIG SUR – an elegant coffee table made up of glass sheets available in four different colours. Differently combined glass sheets create different light effects. BIG SUR is an area of California with dramatic views, run through by the iconic Highway 1.





Ropemaker

TAF ARCHITECTS

The new ROPEMAKER rug collection complements Fogia's existing rug range with vibrant monochrome rugs that exude energy and texture thanks to the materials and technology used. As the name suggests, ROPEMAKER is inspired by classic rope making. Rope and cords are interestingly twisted and wound given the variation in the colour, material and thickness of the different threads. The rug takes on the strength of a twisted rope – both visually and literally.



Ceramics

CARINA SETH ANDERSSON

Carina Seth Andersson's passionate ceramic forms and vessels – weighty and purposeful, with a sense of monumentalism – made in Italy by flame and hand. Stoneware with salt-glazed surface, making them shift in different colors of brown, with each one individual; they're industrially made but utterly unique in every way. And perfect for fruit, plants, novelties, umbrellas...



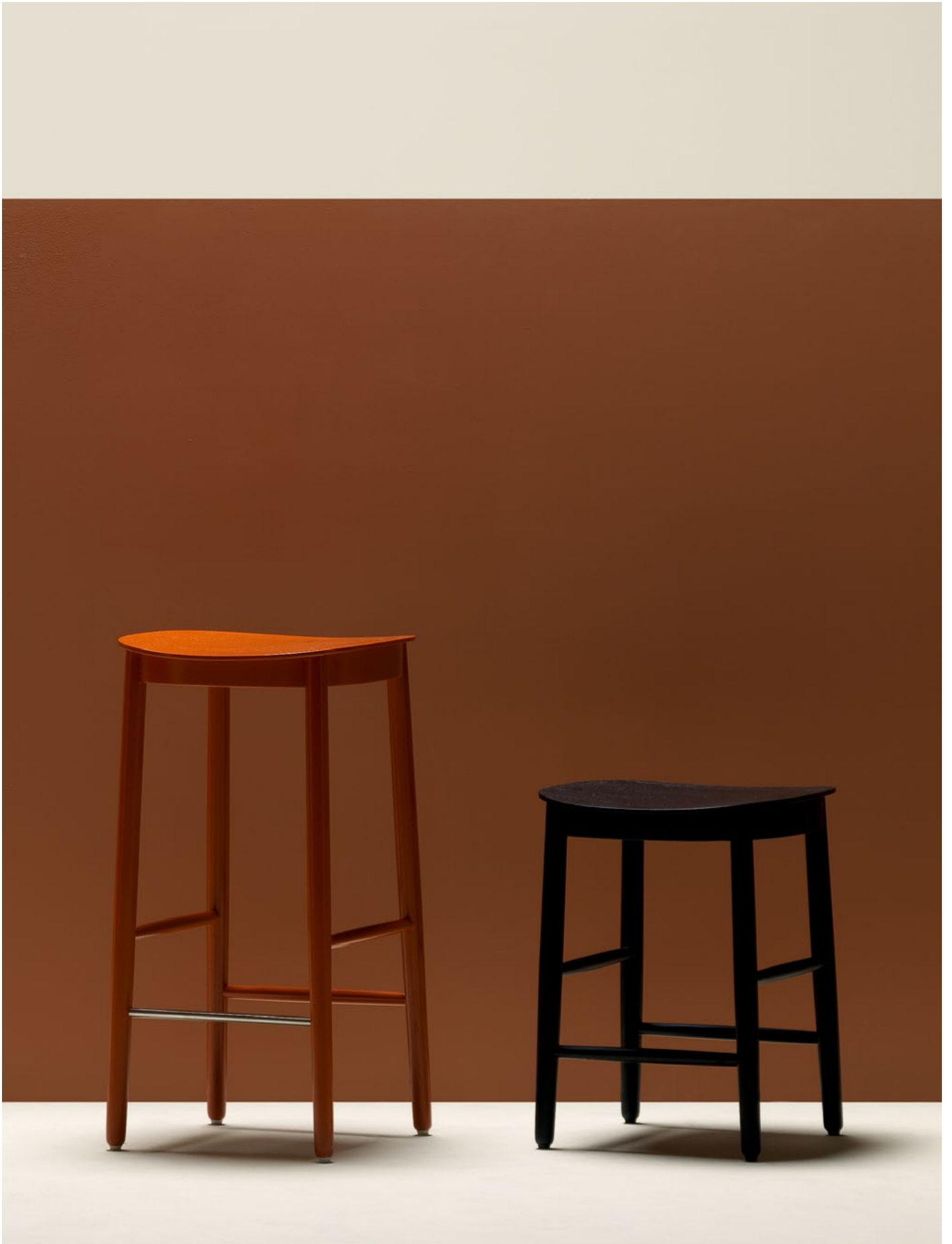



Figurine stool

NOTE DESIGN STUDIO

The Figurine stool is a natural addition to the Figurine family and is designed for the home, where timeless design has to be balanced with impeccable quality. A range of good, classic stools that are with you for life – their design resistant to changing trends and tastes.



Figurine

NOTE DESIGN STUDIO

A harmonious character with a welcoming charm, is how Note would describe Figurine if it were a person. The chair is created for the home environment, where a timeless design has to be matched with impeccable quality. A good, classic chair will follow you for life; its shape and design withstanding fickle trends and changes in tastes. Figurine is our first chair in a decade – an elegant wooden chair with its feet firmly on the ground.







Figurine table

NOTE DESIGN STUDIO

The shape of the table expresses a complicated simplicity with geometric forms. Round legs turn oval where they meet the rectangular tabletop. Figurine is equally at home in the kitchen as it is in the dining room and is sturdy and stable. Seating eight, the table offers plenty of space for gatherings.

Dini

ANDREAS ENGESVIK

DINI sees Andreas Engesvik challenging the old stereotypes of what a sofa should look like with a new, updated, elegant and subdued variation on a typical sofa, with a modern twist. Design-wise DINI firmly belongs in the Scandinavian family – timeless design that just gets better with age.









Pastille

TAF ARCHITECTS

The name Pastille comes from the bulbous round shape of the table top, which feels like a smooth, round tablet. In designing the table, inspiration came from creating a balance between slim and robust shapes. The juxtaposition of elegant, slim metal and solid wooden tops creates an exciting contrast – craftsmanship and materials coming together.



Tiki

ANDREAS ENGESVIK

Tiki is a deceptively simple sofa with an abundance of character and comfort. Its soft lines and worn-in appearance make it feel almost familiar. It's a piece designed to be experienced, inviting the user to touch and explore its construction. Tiki comes with a matching stool, two-seater and armchairs.





Poppy

NINA JOBS

The name Poppy aptly describes its shape. The round, quilted shape of the pouf is reminiscent of a beautiful flower with petals spreading out, or a pastry, or Japanese lanterns. The beautiful shape proved a challenge, really putting Fogia's craftsmanship to the test. It looks simple, but it isn't.







Bollo

ANDREAS ENGESVIK

Bollo has a strong character inspired by its heightened level of comfort, with generously shaped cushions and a bold appearance. Soft volumes reach out to embrace the slim metal base, emphasizing the interesting intersection between the base and its cushions. The final result is a typical Scandinavian lounge chair driven by comfort, both visually and in use.



Koster

NOTE DESIGN STUDIO

These blankets are named after a rainy island on Sweden's west coast. Their colourways take tones from those moments when the sun breaks its way through sheets of rain; with that intense, deep colour that the sea takes on crossing each rug horizontally. Drops of rain spatter over the top of the rugs; a cheeky ironic antidote to adverse conditions inside or out.





Campo

STEFAN BORSELIUS

The centre of the home, somewhere to relax, perch upon, read, gather. With its ellipse armrests and plush down-filled cushions there's a friendliness to Campo, and its warmth seems to fill any space. Made to be a sofa you don't want to rise from; a promise it keeps with integrity and style.





Supper round

ANDREAS ENGESVIK

The Supper round dining table is simple and elegant, and ticks all the boxes when it comes to functionality. The table has a delicate aesthetic, slender proportions and a visual lightness. Its round shape creates a pleasant place for conversations and socialising, as no-one around the table is too far away for a chat.



Supper

ANDREAS ENGESVIK

Supper is a simple and elegant dining table that does not compromise on functionality. Despite its convenient expanding feature, Supper still possess a delicate aesthetic, with slim proportions and a visual lightness. Whether you have guests over or for everyday use, it is the perfect table to gather around.





Supper table
Figurine chair
Land rug

Bowl

ANDREAS ENGESVIK

Bowl is an aesthetically strong storage unit to keep your everyday items close to hand. A true piece of mono-function furniture, items placed within take on a new aesthetic meaning, whether you choose to be creative with your selection of items or a little more haphazard.





Bowl Small
ø 400 mm
height 355 mm

Bowl Big
ø 600 mm
height 355 mm



Land

NOTE DESIGN STUDIO

Land began as an exploration of colour; to find compositions that are dynamic yet discreet, and images of nature provided the starting elements of shape and colour. The results are like a slice of 'mini architecture', where each rug looks like it's been lifted from a piece of something altogether larger in scale.





Arch

NOTE DESIGN STUDIO

A shelf has to be functional above all else, yet sometimes function overpowers any aesthetic intentions it might have. The modular shelf Arch strips the design of the bookshelf back to its basic requirements (a load-bearing shelf) and then adds a simple aesthetic charm in classic bent wood. One shelf you'll not leave hanging when you move house.





Archetto

NOTE DESIGN STUDIO

Archetto is a smaller sibling to the Arch series. A wall mounted shelf that offers a generous surface for your most precious items. Archetto works great in a group to cover a whole wall or as a single.



Sling

width 670 mm

depth 750 mm

height 880

Seating measurements

depth 490 mm

height 430 mm





Sling

NOTE DESIGN STUDIO

Sling is a distinctive armchair, with contrasts of hard and soft from every angle. Its metal frame gives an impression of strength, against upholstery in soft tones and tactile textile. A classic study of modern Scandinavian design for home or public space.



Tabula

NOTE DESIGN STUDIO

Material intensity meets simple lines in the series of tables we call Tabula. Standing alone, or as part of a group, Tabula is a rich piece with thick leather detailing and topped with beautiful terrazzo. Referencing lines from the past, and bringing them into the future.



Tondo (left)
width 1420 mm
depth 710 mm
height 1210 mm

Tondo (right)
width 1870 mm
depth 1760 mm
height 745 mm

Seating measurements
depth 480 mm
height 430 mm



Tondo

STEFAN BORSELIUS

Tondo Sofa is a demonstration of creativity meeting precise craftsmanship. A minimalistic yet soft sofa, in intelligent colourways, it's a piece that sits in all contexts — domestic or public. Its precise form stands on delicate legs in ash, yet it's forgiving and welcoming. Tondo Sofa comes in lowback, armchair, high-backed club variations and with a number of sidetables.





Sam

BORSELIUS/ENGESVIK/NOTE

Sam – short for *Samarbete*, meaning collaboration in Swedish – is a range of versatile tables, visually light as the legs are attached separately to the table top. The shape of the table top and the leg mounting detailing gives Sam a soft and functional appearance.



Retreat

MONICA FÖRSTER

Retreat is a timeless modular sofa made to withstand passing trends. Bold yet soft, Retreat is based around an undulating base unit that can be tailored to make areas of cosy reflection or opened up for festivities.



Retreat
width 3510 mm
depth 1280 mm
height 720 mm





Area

NOTE DESIGN STUDIO

Area is a series of smaller tables that complement Fogia's other products well. The top appears to hover just above the legs which gives a lighter impression. The construction is honest and straightforward, with an artisan spirit. This relates to a classic design tradition with simple, clean Scandinavian lines.



Area Tall
ø 45 cm
height 42 cm

Area Wide
ø 80 cm
height 28 cm

Area Wide Tall
ø 80 cm
height 39 cm

Morris

ANIKA REUTERSWÄRD

Morris is one of our most popular sofas and one reason is the many choices Morris offers – combine as you like and dress it in any of our carefully selected fabrics. Morris is available in two main versions, the classic Morris and lounge version Morris Low.







Rest

NOTE DESIGN STUDIO

The Rest cushions are made with soft textural fabrics and colours ranging from playful accents to pared back neutrals. With multiple sizes to select from – each cushion also has a textured face and a flat, more discreet side for more variation.







Alex

KONCEPT STOCKHOLM

The Alex sofa series is one of our most popular and is also available as low, high and extra deep – providing endless combination possibilities. It's made from the ground up according to solid craftsmanship traditions in our own factory. The hardwood frames and edge-stitched cushions with removable covers give Alex a long and comfortable life.



Boss

BO WESTERDAHL

Boss is a classic yet modern storage series by Bo Westerdaahl, inspired by 1950's Scandinavian style. Boss is designed to be functional, living furniture where great consideration is given to the material, providing quality to the everyday life. Available in many sizes, with both wooden and metal legs.





Rise

NOTE DESIGN STUDIO

Rise is classically elegant with strong individual expression. It carries a Scandinavian identity through its clear wooden base and adds a soft fabric-covered back resting on the top. This enclosing back screens the sofa from an open floor plan.



SOFAS



Retreat



Jord



Tondo



Sling sofa

Rise



ARMCHAIRS

Sling

Bollo

Tiki

Alex



Tondo



Dini



Tiki



Morris Low



Morris



Edward



Campo



Stockholm



Wing



Alex



Alex Classic



Alex High



Douglas



Wing



Crocket



Chili



Morris Low Loveseat



Julia



Lukas



Jord

TABLES



Bowl



Area



Big Sur



Bas



Copper



Pastille



Tabula



Combiplx



Figurine



Sam



Gustav

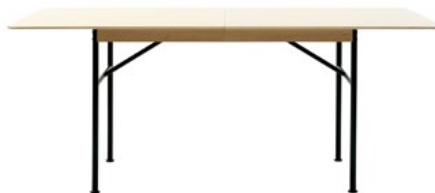

Supper



Supper Round



Tiki



Rise



Campo



Wing



Alex



Julia



Edward



Morris



Palett



Poppy Large



Poppy Small



Anton



Filip



Anika



Ulrika



Figurine



Figurine high stool



Figurine stool

STORAGE



Boss



Archetto



Arch Low



Arch Mini

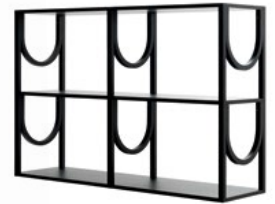

Arch High

ACCESSORIES



Ceramics Planter



Ceramics Plate



Ceramics Pot



Umbrella Stand



Pluto Small



Pluto Large



Luft Small



Luft Large



Cushion colors - front/back

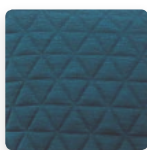
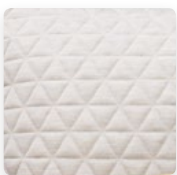

Rest cushions

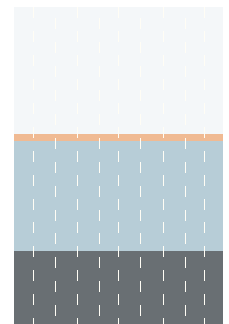
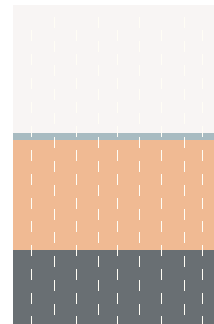
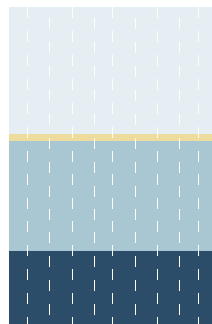

Koster blankets



Land – Forest



Land – Field

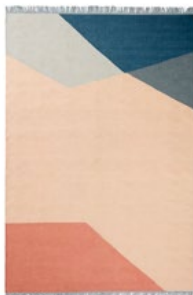

Land – Valley

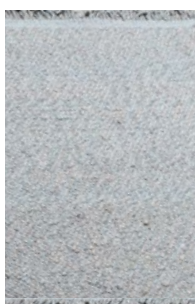

Ropemaker Grey

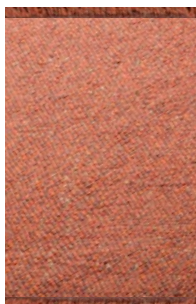

Ropemaker Red



Ropemaker Sand



Ropemaker Black/White

SURFACES

OAK

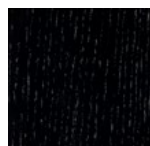

Black

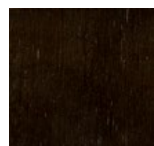

Wenge

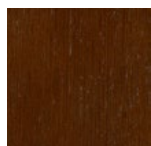

Walnut

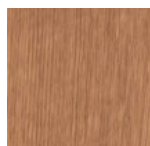

Laquered

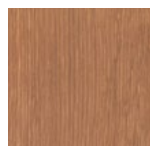

Oiled



Natural laquer

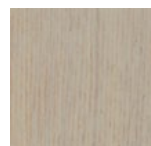

White Pigment



Grey

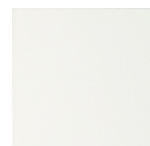

White

ASH

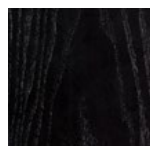

Black

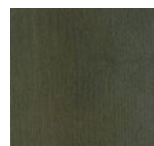

Dark Green

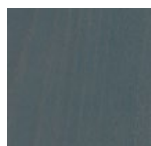

Dark Blue

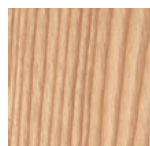

Laquered

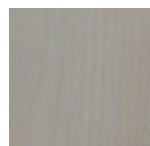

Light Grey

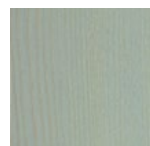

Light Green

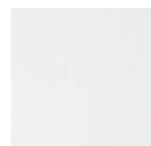

White

METAL



Black
RAL 9005



Black Grey
RAL 7021



Agate Grey
RAL 7038

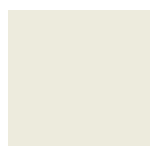

Oyster White
RAL 1013

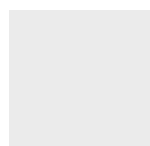

White
RAL 9003



Copper Brown
RAL 8004

THE DESIGNERS

Andreas Engesvik

Andreas Engesvik's design is rich and thoughtful, drawing on his art and design education to create work that explores thematic use of craft skills and industrial design, often with references to his native Norway.

Stefan Borselius

Stefan Borselius is an enigmatic Swedish creator; a skilled carpenter with the design credentials to match. Innovation of form lie at the centre of his work, all underpinned with this craftsman's sharp attention to detail.

Bo Westerdahl

Bo Westerdahl comes from a family that for generations has been involved in furniture manufacture and design, creating an interest in all stages of the manufacturing process and a keen sensitivity to the choice and combination of materials.

Carina Seth Andersson

Carina works with clients and museums both nationally and internationally. The combination of her studio production commissioned for partners and public works is an exchange in which one gives energy to the other.

Luca Nichetto

Born in Venice, Italy Luca has been awarded numerous international design awards for his highly researched, innovative design projects, which range across products, furniture and accessories, architecture and exhibitions.

TAF Architects

The use and the questioning of references is something that is constantly up to date in TAF's rich work process. Inspiration is often unexpected: a piece of candy becomes a table, a rope to be a rug and a hoodie makes an armchair.

Note

Note Design Studio is an internationally acclaimed studio founded in Stockholm 2008. By examining the idiosyncrasies in each project, it creates objects that blend unexpected materials with a tactility virtually unmatched in design.

Monica Förster

Monica Förster is one of Sweden's most awarded designers and has collaborated with many of the biggest names in design. Her style mixes refined function with a fervent curiosity for new techniques, materials and methods.

Anika Reuterswärd

For over thirty years Anika has designed some sixty popular products in Fogia's collection. She makes furniture for everyday life – timeless and beautiful, with roots in Swedish tradition, where simplicity and ease of use are key.

Koncept Stockholm

Koncept Stockholm was founded in 1996 and works with business support architecture and design in the retail, hotel and restaurant, office and home segments.

Simon Klenell/Kristoffer Sundin

Simon has a background in glass making and Kristoffer in furniture design and cabinet making. Their respective skills often lead them into material based experiments, the practical conditions of manufacture and the poetry found in between.

Nina Jobs

Nina Jobs is an internationally renowned product designer. Her way of working, creating is quite low-key and she likes expressions that are easy to apply. Detailed, rational, preferably with a clever construction that is persistent

FOGIA MARKET – Experience the collection live



Fogia Market is many things. It is our workplace, our store, our showroom and the only place where all of our products are gathered under one roof. Here you can quietly sit, try the furniture, browse swatches and get tips and advice from our knowledgeable and experienced sales team. Fogia Market is beautifully situated close to the sea at the entrance of the Swedish capital, Stockholm.

VISIT US: Finnboda Varvsväg 19 A, Nacka, Sweden

Sections All parts can be mirrored

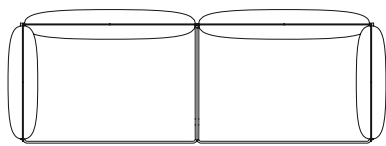

2,5-seater with armrest
310 cm

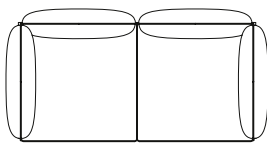

2-seater with armrests
215 cm

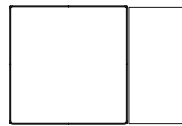

Small pouf + side table
145 cm

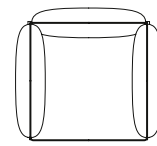

Armchair
120 cm

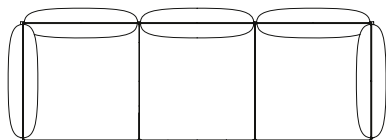

3-seater with armrests
298 cm

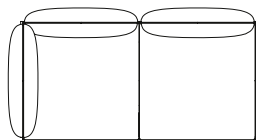

2-seater + armrest
203 cm

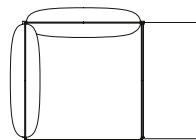

1-seater + armrest + side table
158 cm

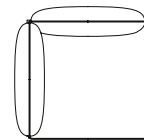

1-seater + armrest
108 cm

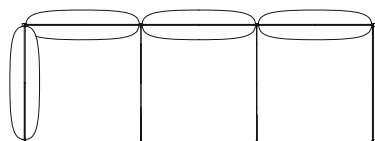

3-seater, one armrest
298 cm

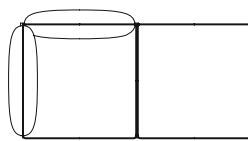

1-seater + armrest + small pouf
310 cm



Big pouf
143 cm

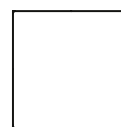

Small pouf
95 cm

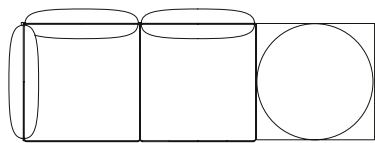

2-seater, one armrest + big table w. round table top
298 cm

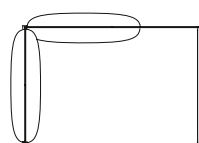

Chaise longue
155 cm

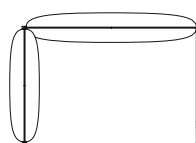

1,5-seater + armrest
155 cm

Total height 68 cm
Seat height 38 cm
Seat depth 83 cm
Sofa depth 108 cm
Pouf depth 95 cm

Example combinations All parts can be mirrored

310 cm

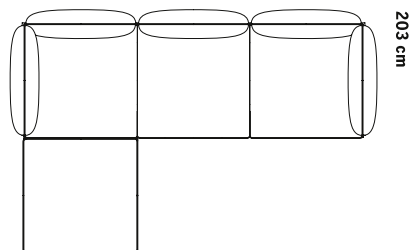

203 cm

310 cm

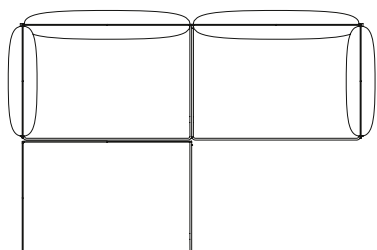

203 cm

310 cm

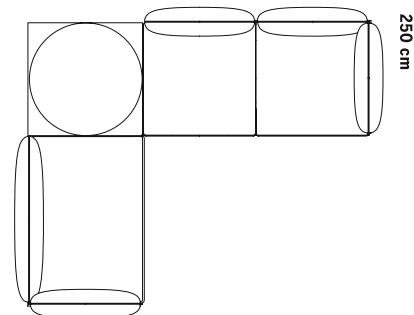

250 cm

358 cm

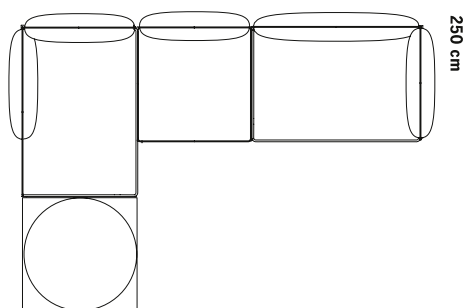

250 cm

458 cm

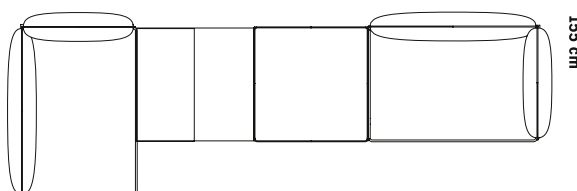

155 cm

1-SEATS

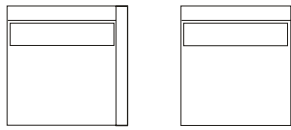

2-SEATS

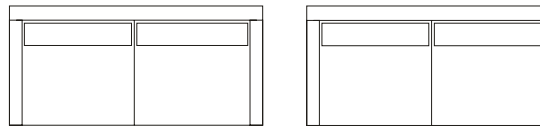

100 cm

2,5- SEATS

240 cm



225 cm

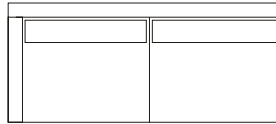

210 cm

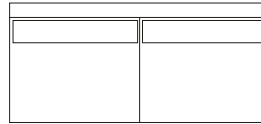

100 cm

CHAISE

90 cm

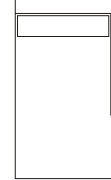

180 cm

OTHER DIMENSIONS

Total height	74 cm
Armrest height	57 cm
Seat height	47 cm
Seat depth	55 cm

3-SEATS

240 cm

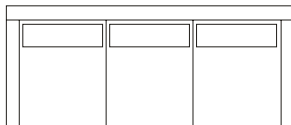

225 cm

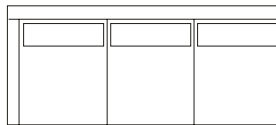

210 cm



100 cm

ARMCHAIR/FOOTREST

85 cm

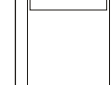

92 cm

85 cm



85 cm

MORRIS LOW LOVE SEAT

165 cm

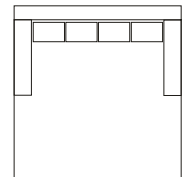

165 cm

Example combinations

290 cm 2-sits + schäslong

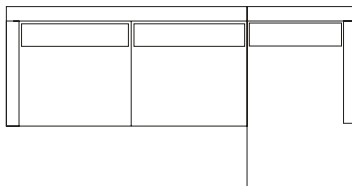

315 cm 2,5-sits + schäslong

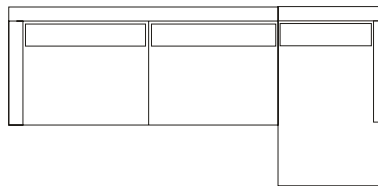

390 cm Schäslong + 2,5-sits + schäslong

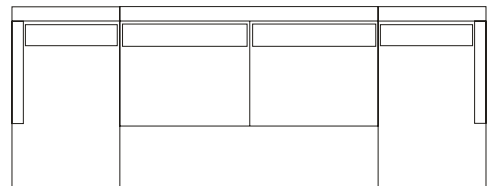

180 cm

302 cm 2-sits + hörn + 2-sits

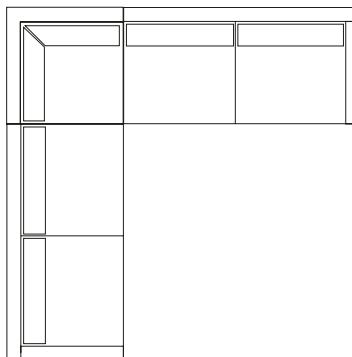

327 cm 2-sits + hörn + 3-sits

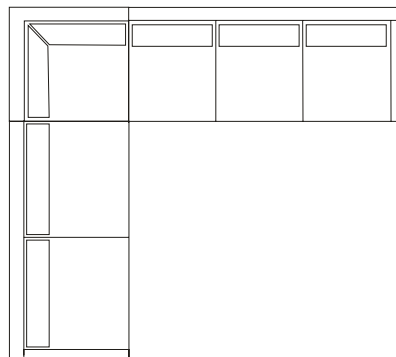

377 cm 2-sits + hörn + 2-sits + schäslong

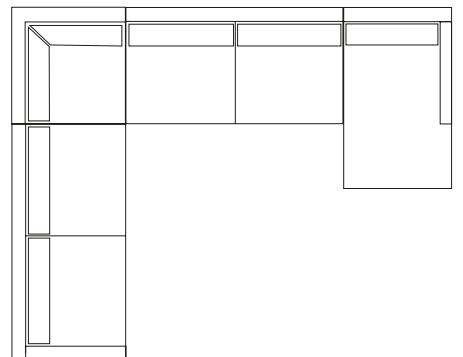

302 cm

Sections All parts can be mirrored

1-SEATS

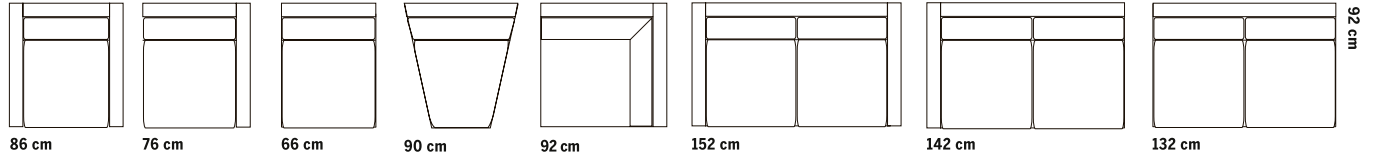

2-SEATS

3-SEATS

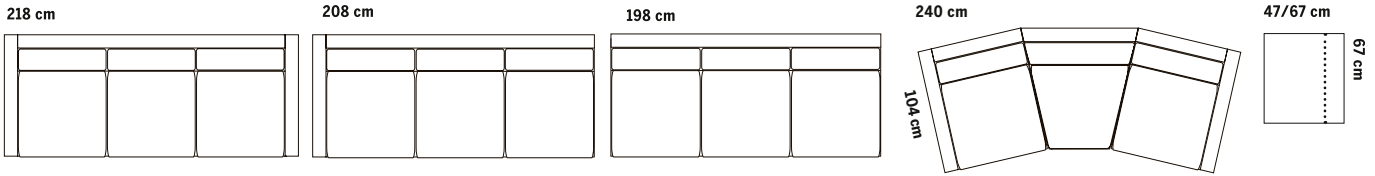

FOOTREST

2.5-SEATS

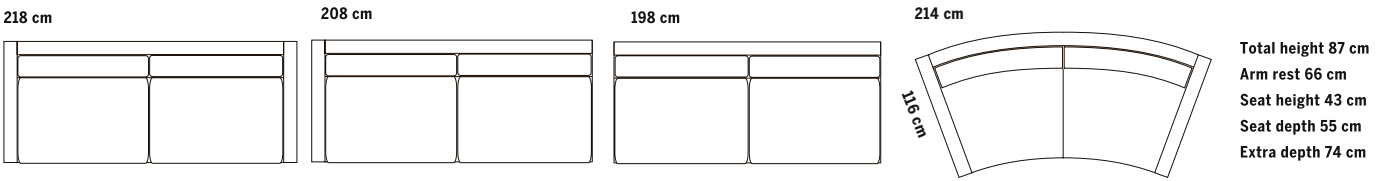

DIMENSIONS

Extra depth

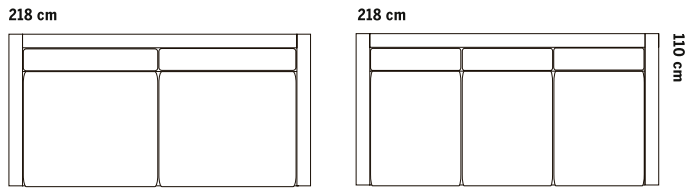

CHAISE

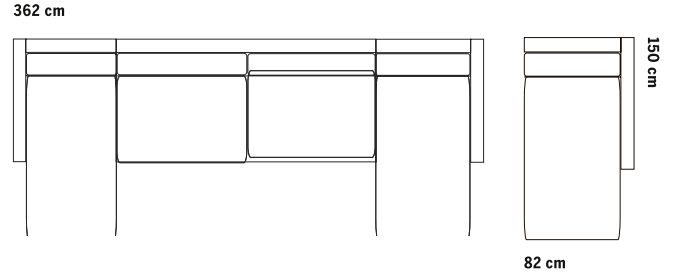

Example combinations

All parts can be mirrored

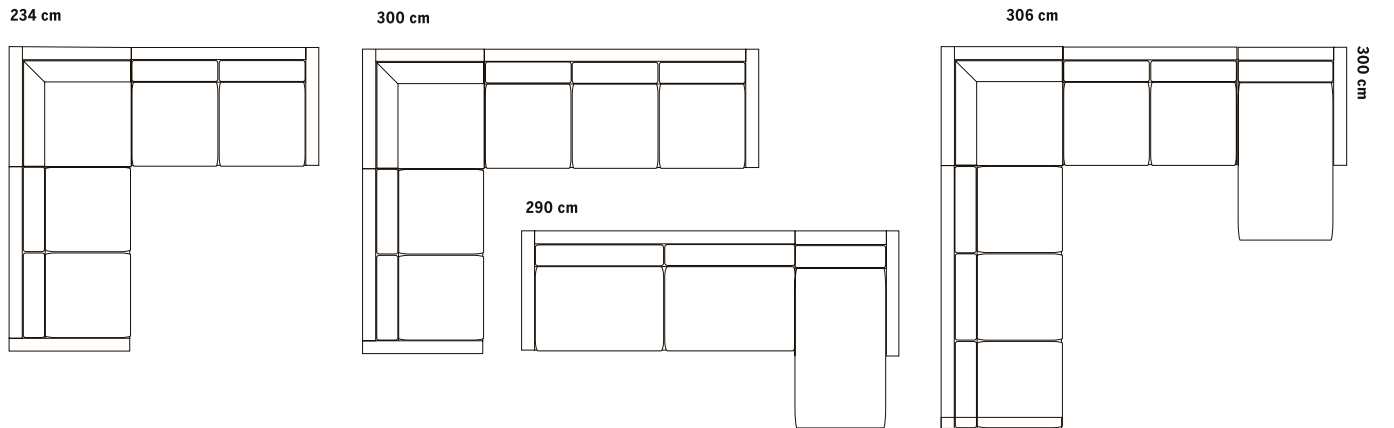

Sections All parts can be mirrored

1-SEATER 1,5-SEATER CORNER 1-SEATER ARMREST 1,5-SEATER ARMREST FOOTREST BIG FOOTREST SMALL OTHER MEASURES

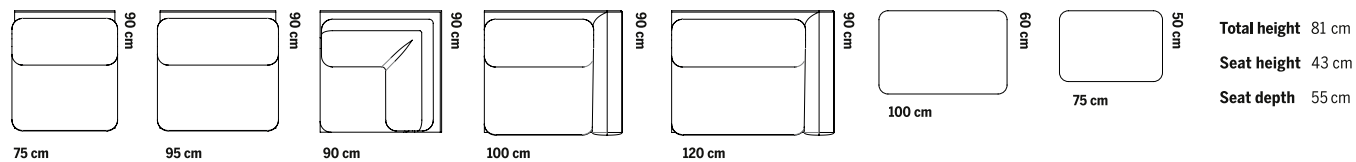

Example combinations

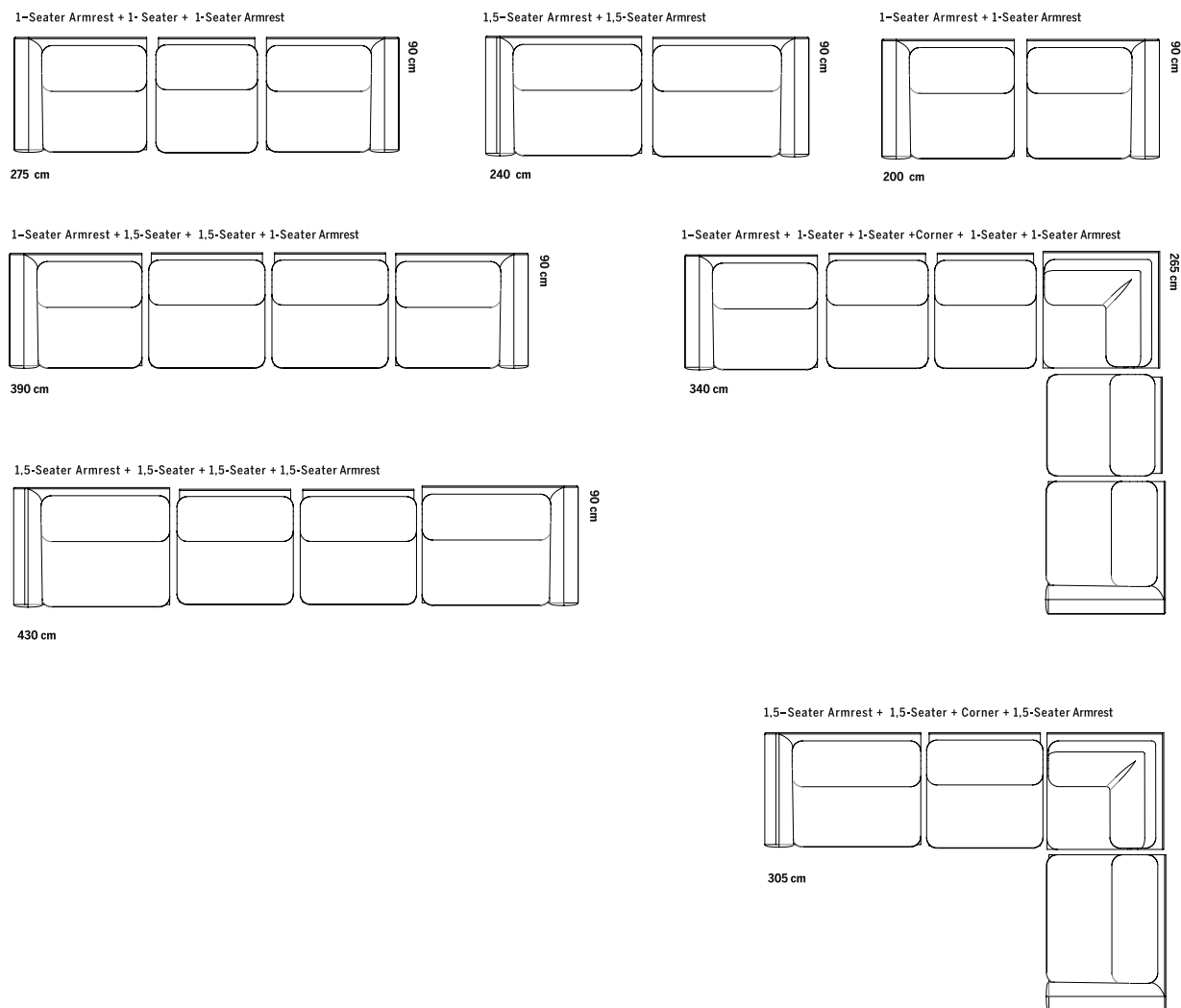

Sections All parts can be mirrored

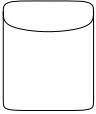
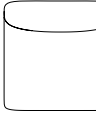
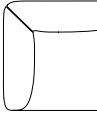
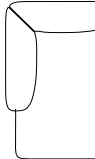
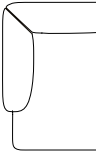
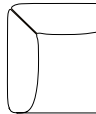
1-SEATER	1,5-SEATER	1,5-SEATER ARMREST	NARROW CHAISE LOUNGE	WIDE CHAISE LOUNGE	CORNER SEAT	OTHER MEASURES
 74 cm	 90 cm	 97 cm	 90 cm	 109 cm	 90 cm	Total height 72 cm Seat height 40 cm Seat depth 58 cm

Example combinations

1,5-seater Armrest + 1,5 Seater + 1,5 Seater

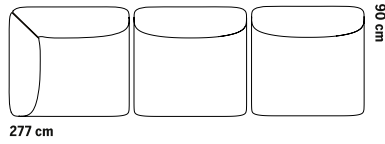

Wide Chaise Lounge + 1-seater + 1,5-seater Armrest

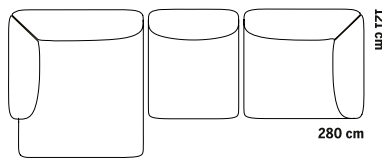

Narrow Chaise Lounge + 1,5-seater + 1-seater + Corner Seat + 1,5-seater + 1,5-seater

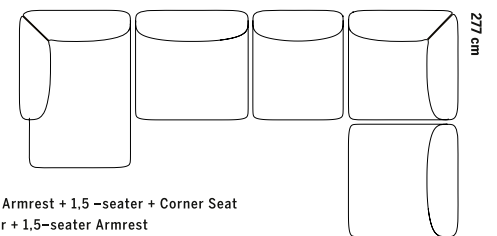

1,5-seater Armrest + 1-seater + 1,5-seater Armrest

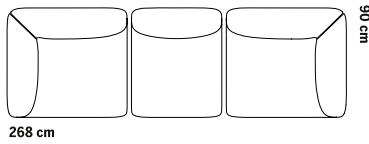

Narrow Chaise Lounge + 1-seater + 1,5-seater

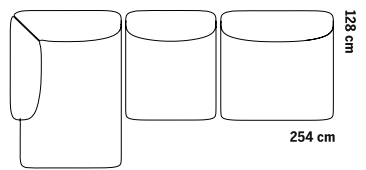

1,5-seater Armrest + 1,5-seater + Corner Seat + 1,5-seater + 1,5-seater Armrest

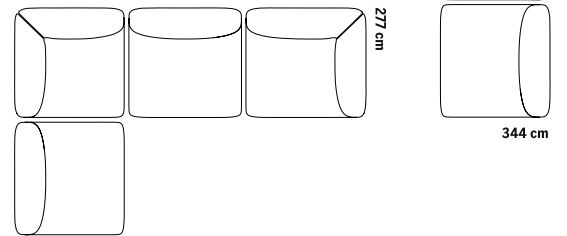

1,5-seater Armrest + 1,5-seater With Armrest

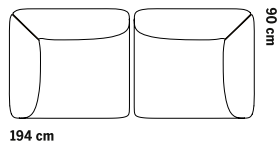

Wide Chaise Lounge + 1,5-seater Armrest

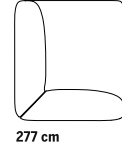
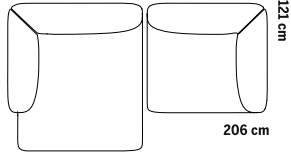

Sections All parts can be mirrored

Total height 74.5 cm
 Seat height 43 cm
 Seat depth 48 cm

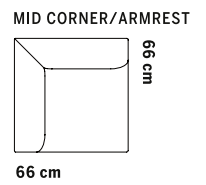
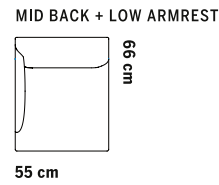
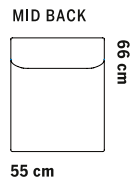

Total height 99 cm
 Seat height 43 cm
 Seat depth 48 cm

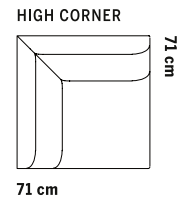
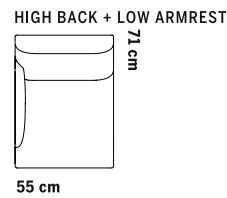
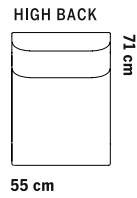

Total height 121 cm
 Seat height 43 cm
 Seat depth 48 cm

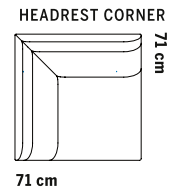
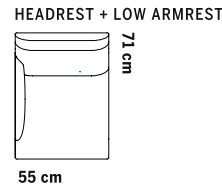
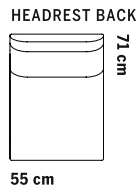

ASSEMBLY TONDO SOFA SYSTEM

Total height 43 cm

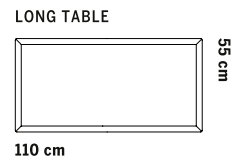
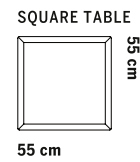
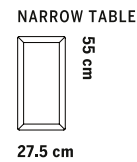
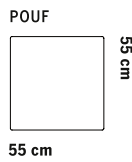

EX.COMBINATIONS

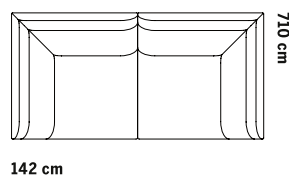
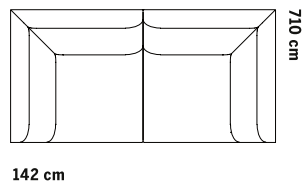
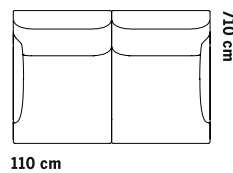
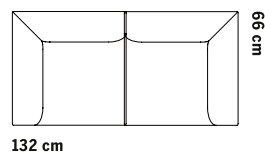
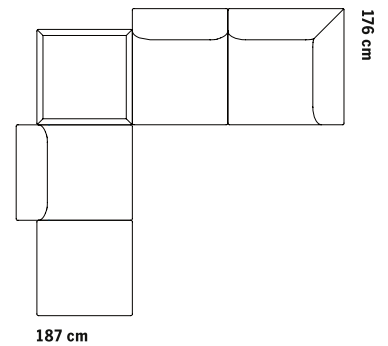
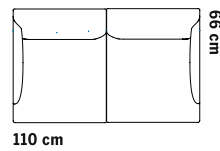
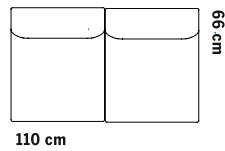

Armchair low back

OTHER MEASURES

Metal frame

58 cm

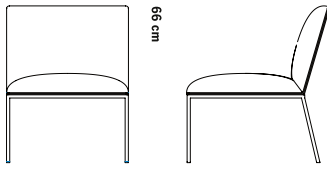

Ash frame

58 cm

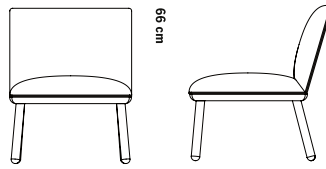

Total height 72/97 cm

Seat height 40 cm

Seat depth 49 cm

With armrest

58 cm

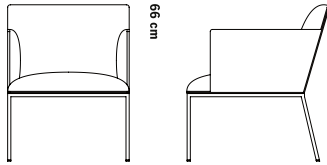

With armrest

58 cm

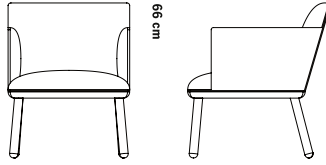

Armchair high back

Metal frame

58 cm

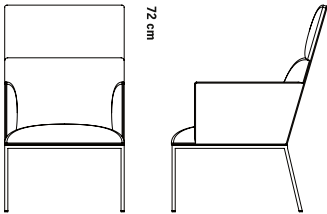

Ash frame

58 cm

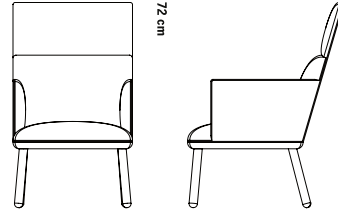

CONTENTS

INTRODUCTION	3	Land	40
Luft	4	Arch	42
Jord	6	Archetto	44
Big Sur	8	Sling	46
Ropemaker	10	Tabula	48
Ceramics	12	Tondo	50
Figurine stool	14	Sam	52
Figurine	16	Retreat	54
Figurine table	18	Area	56
Dini	20	Morris	58
Pastille	22	Rest	60
Tiki	24	Alex	62
Poppy	26	Boss	64
Bollo	28	Rise	66
Koster	30	-----	
Campo	32	OVERVIEW	68
Supper round	34	SURFACES	73
Supper	36	THE DESIGNERS	74
Bowl	38	SOFA SYSTEMS	76

In the world of furniture design it's all too easy to take things how they are, or appear. You head to a showroom with a purpose in mind; a new dining table, sofa or rug perhaps. And there they all are, styled into those attractive room sets. 'Buy me', 'No. Me' is what they say. Sometimes you do. Yet there's more to buying items than that. Because these are items that will live with you, grow with you. Your friends and loved ones will experience them, form their own individual temporary bonds with these pieces of furniture. And each new addition to your life has its own story. A reason for being that's worth telling.

In Fogia's case the story runs deep behind each piece. Rich stories of creative exploration, collaborations across borders and of craft from the hands of passionate, skilled artisans. It's when the stories behind the products are made physical that design becomes truly alive. The bonds we form with the pieces themselves become stronger to break, and we'll celebrate them with others. Tell those stories in analogue forms, people to people, eye to eye. We'll long for the furniture when we're away from home and keep it close to our hearts instead of living from piece to piece.

Fogia's pieces are created by individuals whose story is told through their work. And they're given space and time in which to create and bring forth their narratives. They design without compromise of materials, construction or creative scope. A rarity in this age. Furniture designed without boundaries, specifically for the life you lead today but also tomorrow. Design to be used and cherished. Good design is timeless, and these sagas of creative pursuit are what makes it so.

Studija Amatciems,
Stabu iela 119, Rīga, LV-1009
+371 28647050
info@studija-amatciems.lv
www.studija-amatciems.lv

FOGIA.

 Fogia  @fogiacolection #fogia #fogiacolection

Office & Concept Store Finnboda Varvsväg 19 A, 131 72 Nacka Stockholm Store + 46 (0) 8 55 609 120 Office + 46 (0) 8 55 609 100 www.fogia.se